

PROTOTYPE PROTOTYPE PROTOTYPE

PROTOTYPE PROTOTYPE PROTOTYPE

SALCO PRODUCTS
 PART# TC20NG20
 MATERIAL: FDA NITRILE
 PATENTS:
WWW.SALCOPRODUCTS.COM/LEGAL

SECTION A-A
SCALE 3 : 1

NOTE:
MATERIAL IS BLUE CYAN FDA NITRILE
DURO 60±5 SHORE A

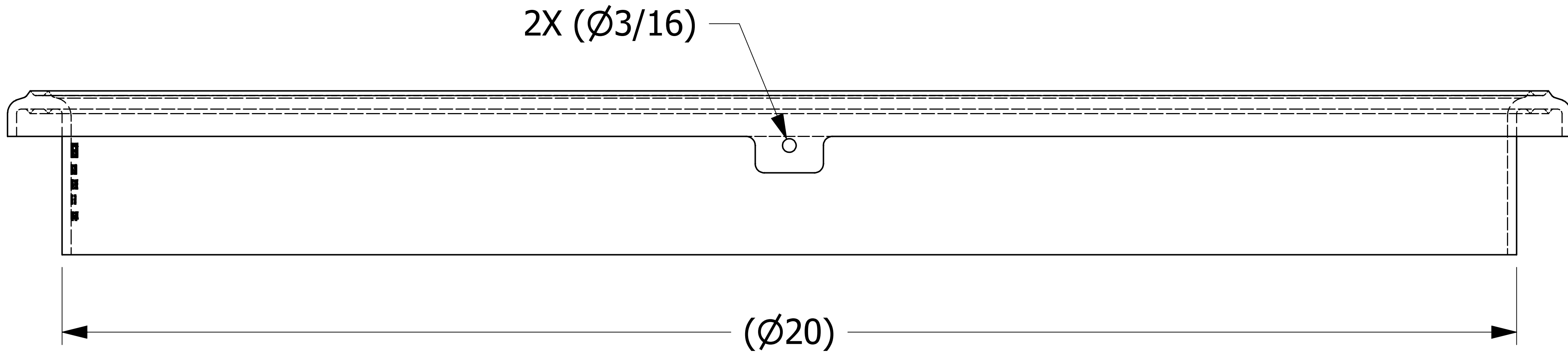

REV	BY	DATE	DESCRIPTION
T	WEB	12-14-15	UPDATED PATENT INFO
S	CHL	11-14-11	UPDATED DIMS IN SECTION B-B & DETAIL C
R	REH	11-23-10	ADDED PATENT PENDING NOTE
Q	CHL	1-5-10	ADDED TOLERANCE TO 80° DIM
P	CHL	10-28-09	ADDED CHEVRONS TO UNDERSIDE OF GASKET
O	BRG	12-14-07	REMOVED CHART

<small>UNLESS OTHERWISE SPECIFIED DIMENSIONAL TOLERANCES FRACTIONAL: ±1/16 X.XX: ±.03 X.XXX: ±.015 ANGULAR: ±1° DEBURR ALL SHARP EDGES. ALL MACHINED SURFACES TO HAVE A 125 RMS FINISH UNLESS NOTED OTHERWISE. THIRD ANGLE PROJECTION</small>	DRAWN BY:	CLH
	CHECKED BY:	AVD
	PROTOTYPE BY:	CLH
	PROTOTYPE DATE:	2/13/1995
	APPROVED FOR PRODUCTION BY:	CLH
	PRODUCTION DATE:	1/15/1997

SALCO PRODUCTS, INC.
PART NAME:
NOZZLE GASKET 20"
MATERIAL:
SEE NOTE
PROJECT #: 961102 SHEET #: 1 OF 1 SCALE: 1:1
DRAWING #: **E24478** PART #: **TC20NG20**